



Western Michigan University
ScholarWorks at WMU

Legacy Scout Tickets from Pure Oil Company

8-20-2021

MGRRE_PureOilScoutTickets_Carl_1_21017105420000

MGRRE

Western Michigan University

Follow this and additional works at: <https://scholarworks.wmich.edu/pure>



Part of the Geology Commons

WMU ScholarWorks Citation

MGRRE, "MGRRE_PureOilScoutTickets_Carl_1_21017105420000" (2021). *Legacy Scout Tickets from Pure Oil Company*. 824.

<https://scholarworks.wmich.edu/pure/824>

This Document is brought to you for free and open access via ScholarWorks at WMU. It has been accepted for inclusion in Legacy Scout Tickets from Pure Oil Company by an authorized administrator of ScholarWorks at WMU. See the National Digital Catalogue - Science Base Catalogue for more collections submitted by MGRRE.



MGRRE_PureOilScoutTickets_Carl_1_21017105420000

API 21017105420000

Permit Number 10542

Lease Name Carl

Well Number 1

County Bay

Township 14N

Range 04E

Section 2

2021 DEQ or Pure co_name Muskegon Development Company

Pure Number 166

Latitude 43.641443

Longitude -83.9685147

THE PURE OIL COMPANY
LOCATION REPORT

Date December 15, 1943 A.F.E. No. _____

Division Mich. Producing District _____ Lease Carl

Acres _____ Lease No. _____ Elevation _____ Well No. 1 (Serial No. 166)

Quadrangle C N 1/2 SW SW Sec. 2 Twp. 14 N Rge. 4 E ~~ENK~~ ~~ENK~~ Monitor

Survey _____ County Bay State Michigan

Operator Gulf Refining Company Map Monitor Twp - Bay Co.

<u>330</u>	<u>330</u>	Feet from North Line of Lease
<u>660</u>	<u>660</u>	" " East " " "
		" " South " " "
<u>660</u>	<u>660</u>	" " West " " "
		Feet from North Line of Section
<u>990</u>	<u>990</u>	" " East " " "
<u>660</u>	<u>660</u>	" " South " <u>1/4</u> "
		" " West " " "

LEGEND

- ☀ Gas Well
- Oil Well
- ☀ Gas - Distillate Well
- or ○ Dry Hole
- Dry Showing Oil
- Location
- ☀ Dry Showing Gas
- ⊗ Abandoned Location
- ☀ or ☀ Abandoned Gas Well
- or ● Abandoned Oil Well
- or ○ Input Well

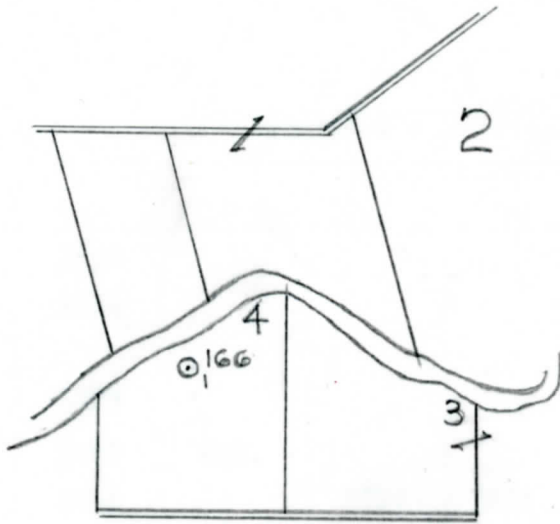

Remarks: _____ Scale _____

Submitted by RN Civil Engineer Approved by _____ Division Manager

Approved by _____ Vice-President - General Manager

COMPLETION RECORD OF WELLS DRILLED BY OTHER OPERATORS

Michigan Producing Division

Date February 9, 1944 No. 166
 State Mich. County Bay Twp. Monitor Sec. 2 Twp. 14 N Rge. 4 E
 Well No. 1 (Serial No.) 166 Farm Carl Acres _____
 Operator Gulf Refining Company Information secured Scouting Department
 Date well started 12-17-43 Date well completed 1-23-44 Elevation 602.0

PRODUCTION BOARD

1st 24 hours natural Filled up 1500 ft.
 2nd 24 hours natural _____
 Date of shot _____ No. of quarts _____ From _____ to _____ From _____ to _____
 Date of acid 2-1-44 No. of gallons 500
 1st 24 hours after acid 116 Barrels (Pumped)
 shot _____
 2nd 24 hours after acid _____

FORMATION AND CASING RECORD

Formation	Top	Bottom	Top Pay	Bottom Pay	Remarks	Casing	
						Size	Set at
Sunbury	1530					10"	84
Berea	1554				Salt water 1580-1600.	8-1/4"	749
						6-5/8"	2772
Antrim	1735						
Traverse Lime	2080	SLM.					
Dundee	2758	"	2820	2835			
			2844	2905			
Total Depth		2912					

Remarks 2075' CTM equals 2086' SLM; 2767' equals 2766' SLM.

Signed D. C. Shackelford